

DETACHED CARPORT DETAILS PLAN AND ELEVATIONS

THIS DRAWING DEPICTS MINIMUM CODE REQUIREMENTS PER CBC 2007. INFORMATION IS FOR REFERENCE ONLY AND IS NOT A SUBSTITUTE FOR ACCURATE DRAWINGS PREPARED FOR EACH PROPOSED CONSTRUCTION PROJECT.

MINIMUM CONSTRUCTION REQUIREMENTS (WHEN LOCATED OUTSIDE OF A HIGH FIRE SEVERITY ZONE)
(CARPORTS LOCATED IN A HIGH FIRE SEVERITY ZONE MAY REQUIRE FIRE DEPT. APPRVL. AND CONDITIONS)

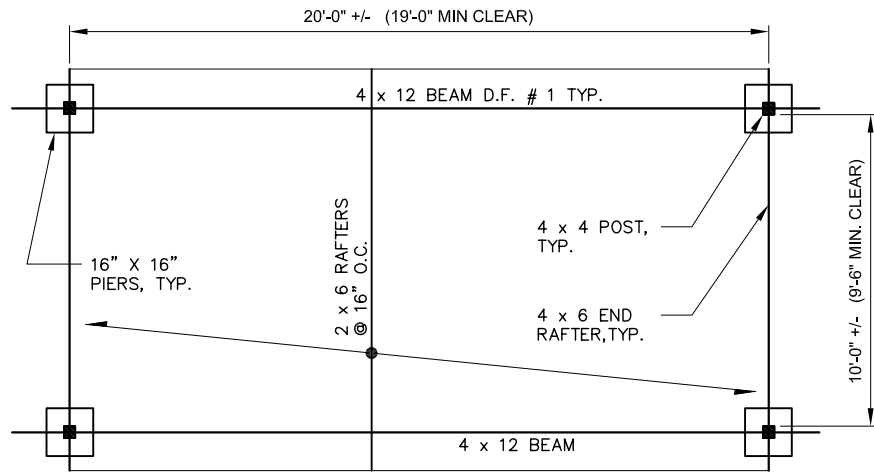
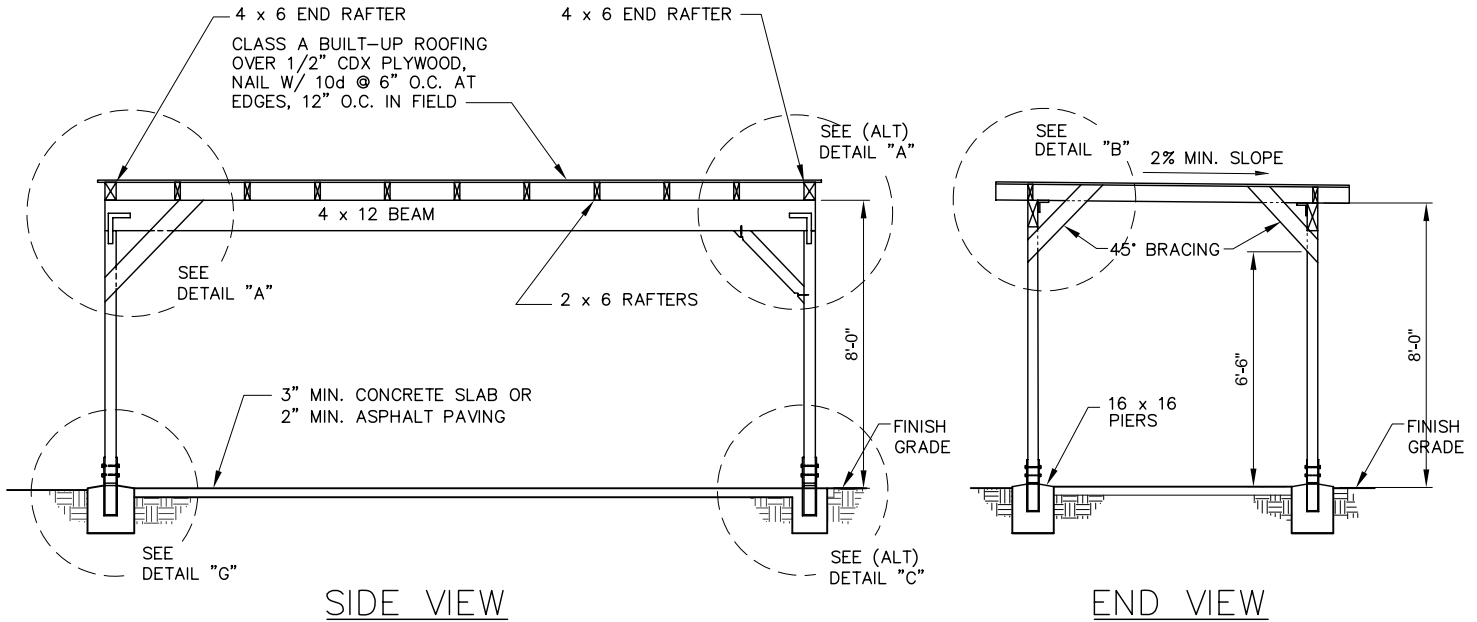

NOTE:

REFER TO TYPE V SHEET FOR SPECIFICATIONS OF CONCRETE, LUMBER GRADE, AND RAFTER SPACING.

PROVIDE PLOT PLAN SHOWING THE LOCATION OF ALL EXISTING BUILDINGS ON LOT WITH DIMENSIONS TO LOT LINES AND BETWEEN BUILDINGS.

THIS STRUCTURE IS NOT PERMITTED WITHIN 5' OF A PROPERTY LINE UNLESS AN EXTERIOR WALL WITHOUT OPENINGS IS PROVIDED. THIS WALL SHALL BE PROTECTED ON THE BOTH SIDES WITH MATERIAL APPROVED FOR 1-HR FIRE RESISTIVE CONSTRUCTION.

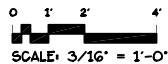

(OVER - FOR DETAILS)

Provide consistent Title Block on all sheets. Leave margin on all sides.

This scale is for example only. Use 1/4" = 1'-0". Typical min. sheet size is 11" x 17"

<p>NAME, ADDRESS AND PHONE NO. OF DESIGNER XXX XXX XXX XXX XXX XXX XXX XXX</p> <p>WET SIGNATURE OF DESIGNER ON EACH SHEET (AND PROFESSIONAL STAMP IF APPLICABLE)</p> <p>E:\Bldg\DLV\ACAD\Details 2\001-DET CAR-1.DWG, 01/30/2009 4:15:47 PM</p>	<p>EXAMPLE RESIDENCE</p> <p>1234 MAIN ST. SANTA ROSA, CA 9540- APN # 000-000-000</p>	<p>DETACHED CARPORT</p> <p>SAMPLE DRAWING</p>	<p>SCALE: 3/16" = 1'-0" DATE: DEC. 15, 2008</p> <hr/> <p>SHEET NO. DC-1</p>
---	---	--	--

DETACHED CARPORT DETAILS

THIS DRAWING DEPICTS MINIMUM CODE REQUIREMENTS PER CBC 2007. INFORMATION IS FOR REFERENCE ONLY AND IS NOT A SUBSTITUTE FOR ACCURATE DRAWINGS PREPARED FOR EACH PROPOSED CONSTRUCTION PROJECT.

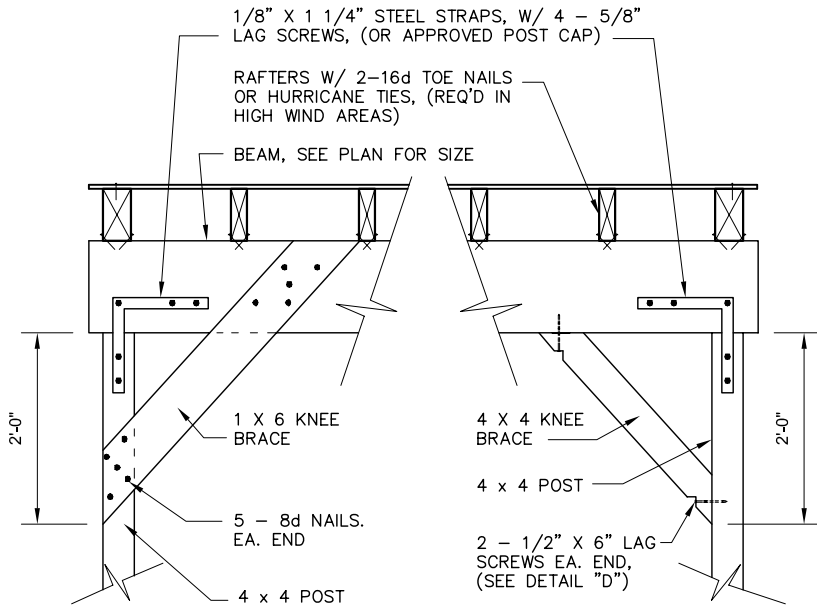

DETAIL "A"

DETAIL "A"
ALTERNATE

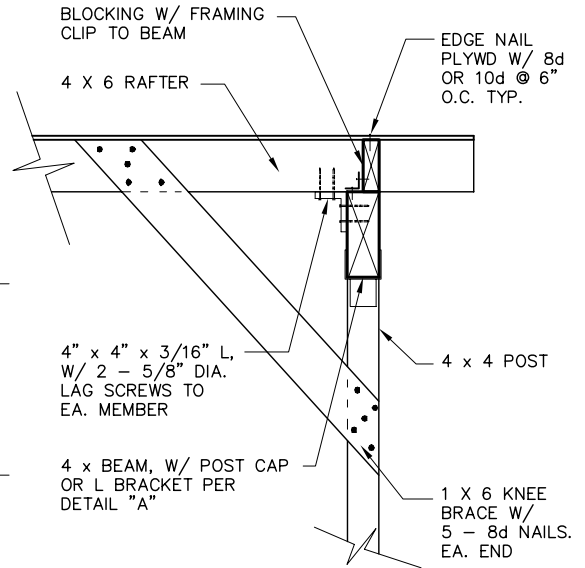

DETAIL "B"

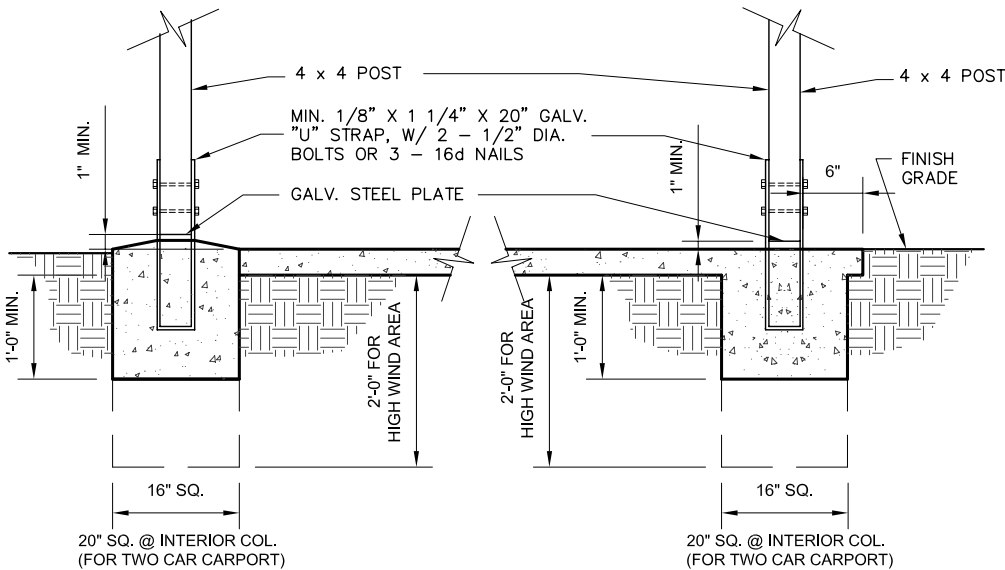

DETAIL "C"

DETAIL "C"
ALTERNATE

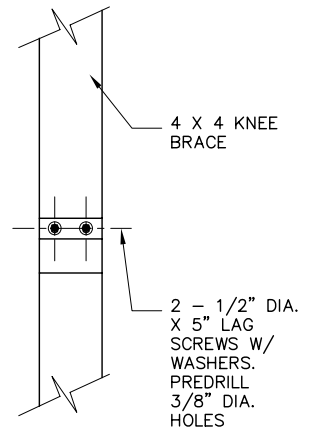

DETAIL "D"

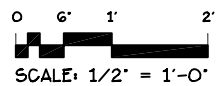

Provide consistent Title Block on all sheets. Leave margin on all sides.

This scale is for example only. Use 3/4" or 1" or 1 1/2" = 1'-0". Typical min. sheet size is 11" x 17"

<p>NAME, ADDRESS AND PHONE NO. OF DESIGNER XXX XXX XXX XXX XXX XXX XXX XXX</p> <p>WET SIGNATURE OF DESIGNER ON EACH SHEET (AND PROFESSIONAL STAMP IF APPLICABLE)</p> <p>E:\Bldg\DLV\ACAD\Details 2\001-DET CAR-1.DWG, 01/30/2009 4:17:51 PM</p>	<p>EXAMPLE RESIDENCE</p> <p>1234 MAIN ST. SANTA ROSA, CA 95400 APN # 000-000-000</p>	<p>DETACHED CARPORT</p> <p>SAMPLE DRAWING</p>	<p>SCALE: 1/2" = 1'-0"</p> <p>DATE: DEC. 15, 2008</p> <p>SHEET NO. DC-2</p>
---	---	--	--