

# WATER HEATER AND EMERGENCY ESCAPE WINDOWS / RESCUE OPENINGS

THIS DRAWING DEPICTS MINIMUM CODE REQUIREMENTS PER THE 2022 CALIFORNIA CODE CYCLE - INFORMATION IS FOR REFERENCE ONLY AND IS NOT A SUBSTITUTE FOR ACCURATE DRAWINGS PREPARED FOR EACH PROPOSED CONSTRUCTION PROJECT

WATER HEATER REPLACEMENTS ARE TO BE OF AN APPROVED EFFICIENCY - SEE <https://cacertappliances.energy.ca.gov/Pages/ApplianceSearch.aspx>

INSULATION IS REQUIRED ON WATER PIPES PER CEnC 150.0(j)(1) AND CPC 609.12

COMBUSTION AIR FOR GAS WATER HEATERS IS REQUIRED PER CPC 506.1

WATER HEATERS LOCATED IN BEDROOMS AND BATHROOMS SHALL HAVE GASKETS AND VENTING PER CPC 504.1

MINIMUM OF TWO SEISMIC STRAPS (ONE AT TOP THIRD, ONE AT BOTTOM THIRD) PER CRC R301.2.2.10 AND CPC 507.2

SEISMIC STRAP SPACED A MINIMUM OF 4" ABOVE CONTROLS (CPC 507.2)

APPLIANCES IN GARAGES ARE TO BE INSTALLED SO THAT ALL BURNERS AND BURNER-IGNITION DEVICES ARE LOCATED NOT LESS THAN 18" ABOVE THE FLOOR UNLESS LISTED AS FLAMMABLE VAPOR IGNITION RESISTANT, AND SHALL BE PROTECTED FROM PHYSICAL DAMAGE PER CPC 507.13

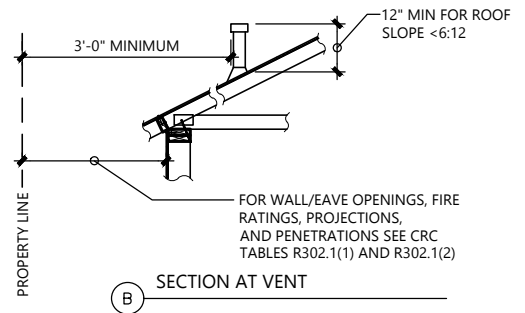
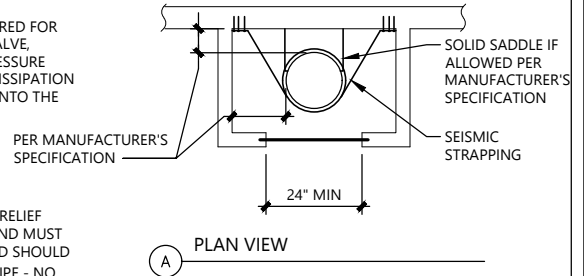
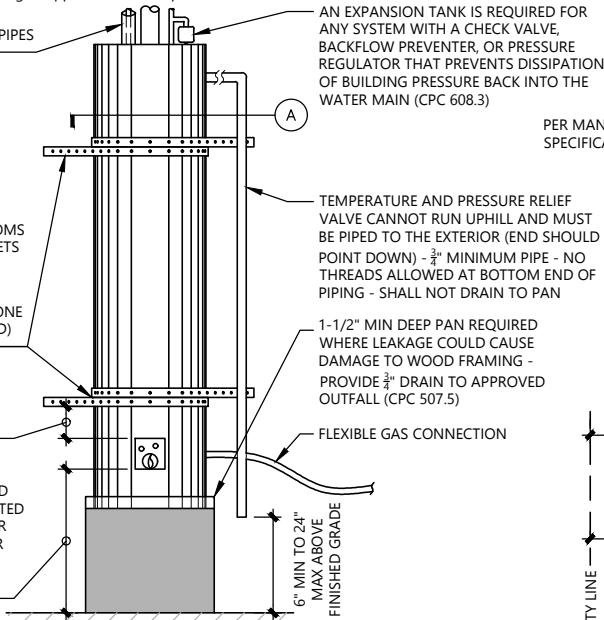

## WATER HEATER

### REPLACEMENT WINDOWS:

PER CBC 505.3 AND CRC R310.5, A REPLACEMENT WINDOW SHALL BE EXEMPT FROM THE REQUIREMENTS OF CBC SECTION 1031.3 AND CRC SECTION R310.2 PROVIDED THE WINDOW MEETS THE FOLLOWING CONDITIONS:

1. THE REPLACEMENT WINDOW IS THE MANUFACTURER'S LARGEST STANDARD SIZE WINDOW THAT WILL FIT WITHIN THE EXISTING FRAME OR EXISTING ROUGH OPENING. THE REPLACEMENT WINDOW IS OF THE SAME OPERATING STYLE AS THE EXISTING WINDOW, OR A STYLE THAT PROVIDES FOR AN EQUAL OR GREATER WINDOW OPENING AREA THAN THE EXISTING WINDOW.
2. THE REPLACEMENT WINDOW IS NOT PART OF A CHANGE OF OCCUPANCY.

### CASEMENT WINDOWS:

(CASEMENT WINDOWS MUST OPEN 90° MINIMUM)

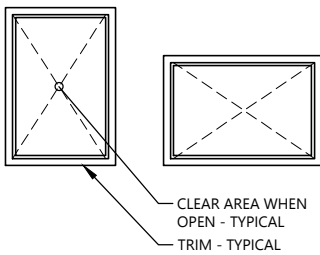

### SINGLE OR DOUBLE HUNG WINDOWS:

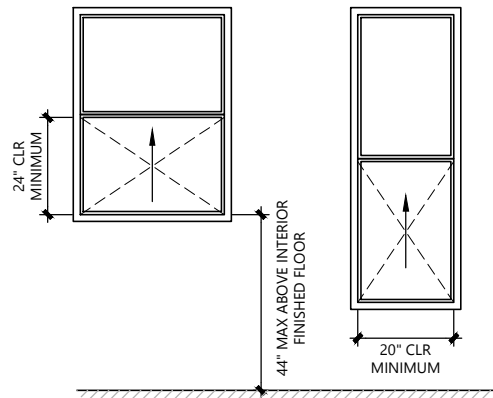

### SLIDER WINDOWS:

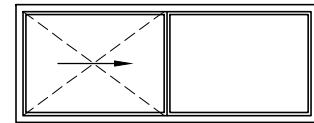

### MINIMUM SIZE REQUIREMENTS FOR EMERGENCY ESCAPE / RESCUE OPENING WINDOWS (CRC R310):

1. 20" CLEAR WIDTH MINIMUM
2. 24" CLEAR HEIGHT MINIMUM
3. 5.7 SF CLEAR AREA MINIMUM  
 EXCEPTION: 5.0 SF CLEAR AREA MINIMUM IF TOP OF WINDOW SILL IS 44" MAXIMUM FROM BOTH INTERIOR TOP OF FLOOR, AND EXTERIOR GRADE AT WINDOW

FOR MULTI-FAMILY RESIDENTIAL APPLICATIONS SEE CBC 1030

## EMERGENCY ESCAPE / RESCUE OPENING